

600 A 15/25 kV class BOL-T™ deadbreak connector



General

Eaton terminates high-voltage underground cable on deadfront apparatus such as transformers, switches and switchgear with its Cooper Power™ series 600 A, 15/25 kV Class BOL-T™ deadbreak connector. It is fully shielded, submersible and meets the requirements of IEEE Std 386™-2006 standard – “Separable Insulated Connector Systems”.

The capacitive test point on the insulating plug provides a means of testing the circuit without disturbing the bolted connection.

In addition to the capacitive test point feature on the insulating plug, Eaton offers an optional capacitive test point similar to the test points on its Cooper Power series 200 A Elbows. This allows the use of the Type “TPR” faulted circuit indicators, and provides a hotstick operable means of determining circuit condition when used with high impedance voltage sensing devices designed for test points.

BOL-T connectors are designed for use on solid dielectric cable (XLPE or EPR) with extruded semi-conductive shields and concentric neutral, with or without a jacket.

Installation on jacketed concentric neutral cable may require additional sealing material. Cold shrinkable adapters are available for tape shield, linear corrugated and drain wire cable adaptation for use with deadbreak connectors.

EATON

Powering Business Worldwide

900 AMP rating

The BOLT connector is rated for 900 A continuous when used with a coppertop compression connector, copper insulating plug, copper stud and copper bushing or junction. If a 900 A rating is desired, specify a "C" as the 9th digit when determining your part number. See Step 3, page 5.

Interchangeability

All Eaton's Cooper Power series 600 A deadbreak connectors conform to the electrical, mechanical and dimensional requirements of IEEE Std 386™-2006 standard. The connectors can be used on any comparably rated bushing interface that also meets the requirements of this standard. In addition all cable adapters, insulating plugs, compression connectors and other component parts are designed to be interchangeable with those currently available from other major manufacturers that also comply with IEEE Std 386™-2006 standard.

Installation

A torque wrench and one-inch socket are used to tighten the insulating plug through the compression or shear bolt connector within the T-body onto a de-energized 600 A bushing interface. Refer to *Service Information MN650005EN 600 A 15/25 kV Class BOLT and Separable Splice Connector Assembly Installation Instructions* for details.

Production tests

Tests conducted in accordance with IEEE Std 386™-2006 standard:

- ac 60 Hz 1 Minute Withstand
 - 40 kV
- Minimum Partial Discharge Extinction Voltage
 - 19 kV

Tests conducted in accordance with Eaton requirements:

- Physical Inspection
- Periodic Dissection
- Periodic X-ray Analysis

Table 1. Voltage Ratings and Characteristics

Description	kV
Standard Voltage Class	25
Maximum Rating Phase-to-Ground	15.2
ac 60 Hz 1 Minute Withstand	40
dc 15 Minute Withstand	78
BIL and Full Wave Crest	125
Minimum Partial Discharge Extinction Voltage	19

Voltage ratings and characteristics are in accordance with IEEE Std 386™-2006 standard.

Table 2. Current Ratings and Characteristics

Description	Amperes
Continuous	600 A rms
4 Hour Overload	900 A rms
Short Time	40,000 A rms symmetrical for 0.17 s 27,000 A rms symmetrical for 4.0 s

Current ratings and characteristics are in accordance with IEEE Std 386™-2006 standard.

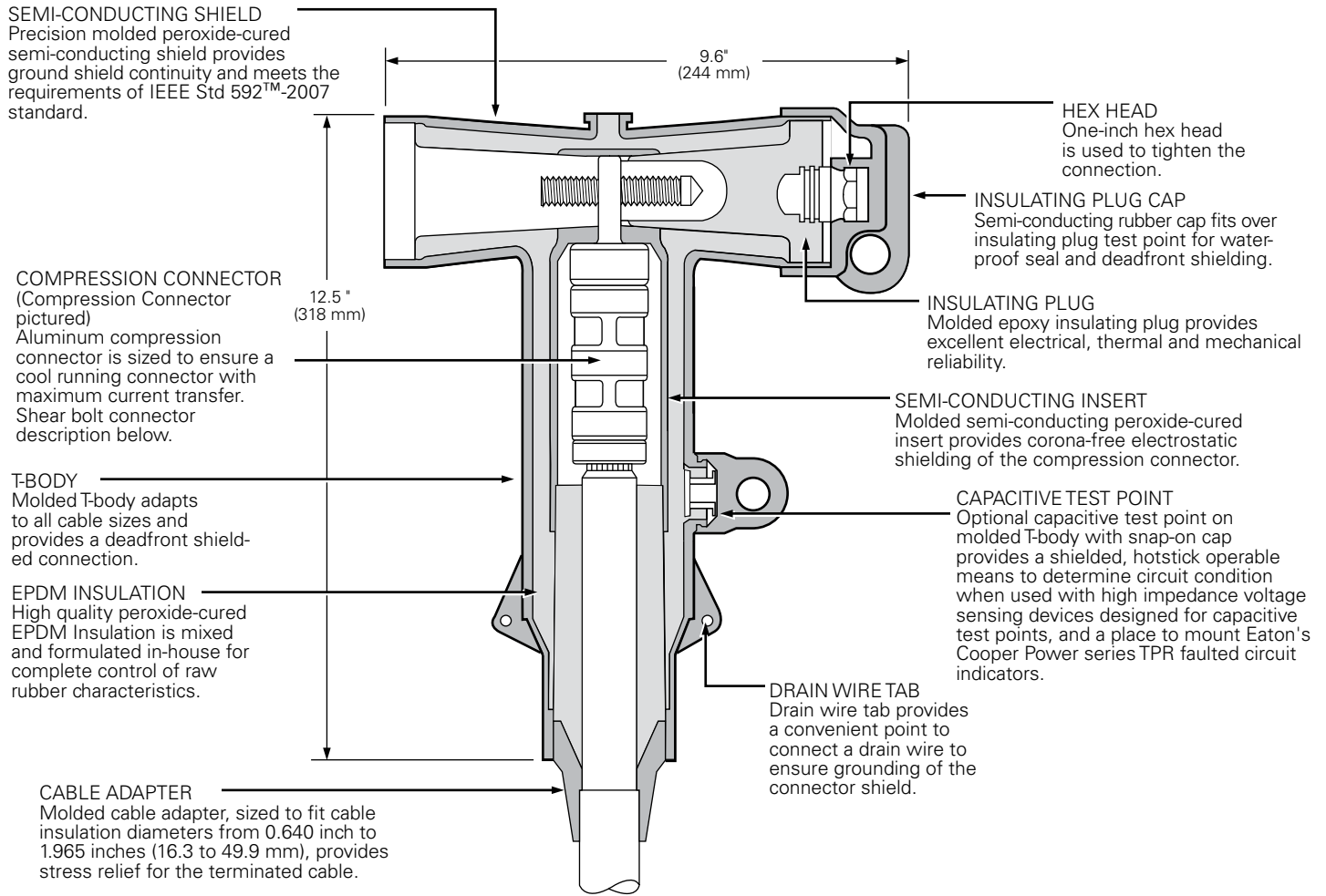

Figure 1. BOL-T Cutaway illustrates design features.

Note: Dimensions given are for reference only.

Optional features

Coppertop compression connectors

Coppertop compression connectors (aluminum sleeve welded to a copper spade) provide a high conductivity material in a bolted connection and are compatible with aluminum or copper conductors.

All copper current path

Full copper current carrying path and 900 A rating can be obtained by specifying a coppertop compression connector, copper stud and copper insulating plug.

Shear bolt connector (optional)

Bolted cable lug is fitted with stepless bolts, which shear off when optimum contact force has been reached. Provides electrical continuity for copper and aluminum conductors while eliminating need for dies and compression tools.



Figure 2. Shear bolt connector.

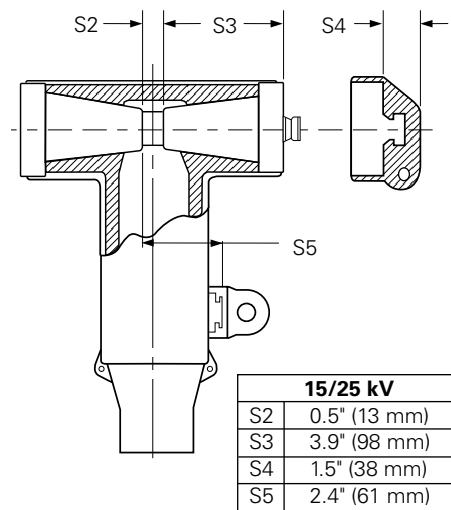

Figure 3. BOL-T stacking dimensions.

Ordering information

Each BOLT Connector Kit contains:

- Molded Rubber T-body
- Insulating Plug
- Insulating Plug Cap
- Compression or Shear Bolt Connector
- Cable Adapter
- Silicone Lubricant
- Installation Instruction Sheet

To order a 15/25 kV Class BOLT Connector Kit, see following Steps 1-5 to build the catalog number.

BOLT connector kit – catalog numbering system

Build the 12 digit catalog number for a BOLT Kit by following the steps given below. The first 5 digits are "BT625", so only digits 6 through 12 need to be selected.

1	2	3	4	5	6	7	8	9	10	11	12
B	T	6	2	5							

Catalog number digits:

1 & 2 = "BT", BOLT Connector System

3 = "6", 600 A System

4 & 5 = "25", 25 kV Class Bushing Interface

Step 1 – Select digits 6 and 7 cable adapter range code

Determine the cable's diameter over the electrical insulation as shown in Figure 4 (including tolerances).

Then identify a cable range from Table 3 that covers the minimum and maximum insulation diameters.

Select the correct CABLE RANGE CODE from Table 3.

Table 3. Cable Diameter Range

Cable Diameter Range		
Inches	mm	Code
0.610-0.970	15.5-24.6	AB
0.750-1.080	19.1-27.4	CC
0.970-1.310	24.6-33.3	DD
1.090-1.470	27.7-37.3	EE
1.260-1.640	32.0-41.7	FF
1.360-1.710	34.5-43.4	GG
1.510-1.850	38.4-47.0	HH
1.700-1.970	43.2-50.0	JJ

Step 2 – Select digits 8 and 9 conductor code

Identify the conductor size and type in Table 4 and select the CONDUCTOR CODE from the appropriate (compression or shear bolt) column.

Step 3 – Select digit 10

Determine whether Aluminum or Copper is required for the compression connector, stud, and deadbreak insulating plug. Shear bolt connector is only available as a 600 A aluminum connector.

"A" = Aluminum (Shear Bolt or Compression Connector)

"C" = Copper (Coppertop for the connector) **Required to achieve 900 A rating, compression connector only.**

Step 4 – Select digit 11

Determine if a stud should be included in the kit.

"1" = Stud Included

"2" = Stud Not Included

Step 5 – Select digit 12

Determine if the T-body should have a test point.

T = Test Point on T-body

If no test point is required, do not include an 12th digit.

EXAMPLE: Select a BOLT Kit for 250 kcmil compressed cable with a nominal insulation diameter of 1.160 ± 0.030 ". The kit should have aluminum current-carrying parts and should have a stud included. The T-Body should have a test point.

Step 1 – Select digits 6 and 7

Nominal diameter over insulation is 1.160 ± 0.030 ".

Minimum diameter = $1.160 - 0.030 = 1.130$ ".

Maximum diameter = $1.160 + 0.030 = 1.190$ ".

From Table 3, identify the cable range that covers 1.130" - 1.190" and select the "EE" cable range code.

Step 2 – Select digits 8 and 9

The conductor size is 250 kcmil compressed. From Table 4, under the column "Concentric or Compressed," identify 250 kcmil and select the "17" conductor code.

Step 3 – Select digit 10

The kit should have aluminum current-carrying parts. Select an "A" for digit 10.

Step 4 – Select digit 11

The kit should include a stud, so select 1 for digit 11.

Step 5 – Select digit 12

A test point is needed, so use a "T" for digit 12.

The complete catalog number is:

BT625EE17A1T

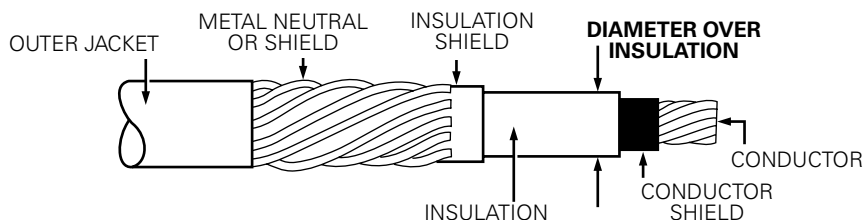

Figure 4. Illustration showing typical construction of medium voltage underground cable.

Table 4. Conductor Size and Type

Compression Connector					Shear Bolt Connector						
Concentric or Compressed		Compact or Solid			Compression Conductor Code	Cable Conductor Size				Shear Bolt Connector	
AWG or kcmil	mm²	AWG or kcmil	mm²	AWG or kcmil			mm² Standard Sizes	Conductor Code	Catalog Number		
				Compact		Compressed	Concentric				
No Connector				0	1/0	1/0	1/0	50			
#2	35	1	-	11	2/0	2/0	2/0	70			
#1	-	1/0	50	12	3/0	3/0	3/0	-	S1	CDT630SB150	
1/0	50	2/0	70	13	4/0	4/0	4/0	95			
2/0	70	3/0	-	14	250	250	250	120			
3/0	-	4/0	95	15	350	-	-	150			
4/0	95	250	120	16	-	350	350	185			
250	120	300	-	17	500	500	500	240	S3	CDT630SB300	
300	-	350	-	18	600	600	600	300			
350	-	400	185	19	700	-	-	-			
400	185	450	-	20	-	700	700	-			
450	-	500	240	21	750	750	750	-	S4	CDT630SB400	
500	240	600	300	22	800	800	-	400			
600	300	700	-	23	900	-	-	-			
650	-	750	-	24							
750	-	900	-	25							
900	-	1000	500	26							
1000	500	-	-	27							
1250	630	-	-	28							

Accessories

Cable adapters, compression connectors, and other accessories that can be used with BOL-T connectors are described in Catalog Data CA650007EN, "Deadbreak Accessories, Tools, and Replacement Parts."

Table 5. Replacement Parts

Description	Catalog Number
T-body without Test Point	DT625
T-body with Test Point	DT625T
T-body without Test Point With Aluminum Stud	DT625SA
T-body without Test Point With Copper Stud	DT625SC
T-body with Test Point With Aluminum Stud	DT625TSA
T-body with Test Point With Copper Stud	DT625TSC
Insulating Plug Cap	DIPCAP
Aluminum Insulating Plug with Cap (No Stud)	DIP625A
Copper Insulating Plug with Cap (No Stud)	DIP625C
Aluminum Insulating Plug with Cap and Aluminum Stud	DIP625AS
Copper Insulating Plug with Cap and Copper Stud	DIP625CS
5/8" – 11 UNC 2A Aluminum Threaded Stud	STUD-A
5/8" – 11 UNC 2A Copper Threaded Stud	STUD-C

This page intentionally left blank.

Eaton
1000 Eaton Boulevard
Cleveland, OH 44122
United States
Eaton.com

Eaton's Cooper Power Systems Division
2300 Badger Drive
Waukesha, WI 53188
United States
Cooperpower.com

© 2015 Eaton
All Rights Reserved
Printed in USA
Publication No. CA650003EN

Eaton, Cooper Power, and BOL-T are valuable trademarks of Eaton in the U.S. and other countries. You are not permitted to use these trademarks without the prior written consent of Eaton.
IEEE Std 386™-2006 and IEEE Std 592™-2007 standards are trademarks of the Institute of Electrical and Electronics Engineers, Inc., (IEEE). This publication is not endorsed or approved by the IEEE.

For Eaton's Cooper Power series BOL-T deadbreak connector product information call 1-877-277-4636 or visit: www.cooperpower.com.